

Foam Roofing around RoofScreen Bases

Introduction:

RoofScreen's Base Supports are perfectly compatible with sprayed foam roofing. However, it is crucial for the foam roofing applicator to be familiar with how the RoofScreen System works to ensure maximum watertight integrity.

The purpose of this bulletin is to explain how the RoofScreen Base Supports are assembled, so that properly applied foam roofing does not interfere with the intended design. It is the responsibility of the roofing applicator to follow guidelines, procedures and installation instructions set forth by the manufacturer of the roofing system being applied.

RoofScreen offers two basic types of supports as illustrated below with information on how to roof them in with foam.

Square Base System:

With the RoofScreen Square Base System, the Base Cap Assembly, as shown in Figure 1, is designed to counter-flash tightly over the Base Support and Flashing (if used), extending down 2.4", with just enough clearance for the Base Gasket to be compressed inside the gap. For this reason, it is critical that expanding foam is NOT applied on the sides of the Base Support or Flashing within 3"-4" from the top of the Base Support or Flashing (see Figure 2).

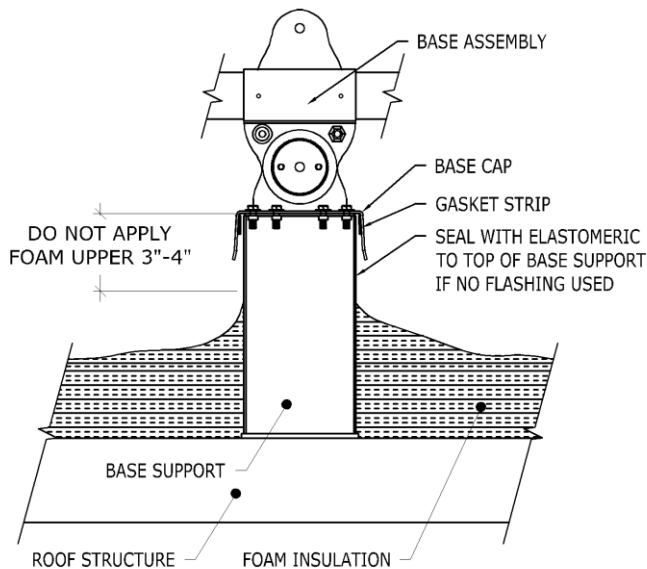

Figure 2

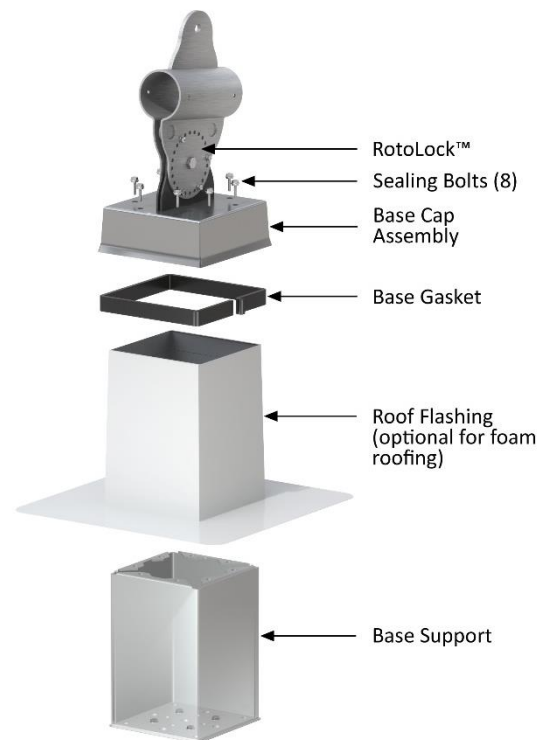

Figure 1

It is important to note that the RoofScreen Base Support is not designed to be left exposed. It has welded seams that are not watertight, and the paint is a primer not a finish paint. Therefore, it is required that the finish elastomeric coating extends up to the top of the Base Support if flashing is not used. This process should be done with the Base Cap Assembly removed (see Figure 3). After the coating has cured, the Gasket Strip and Base Cap Assembly may be installed.

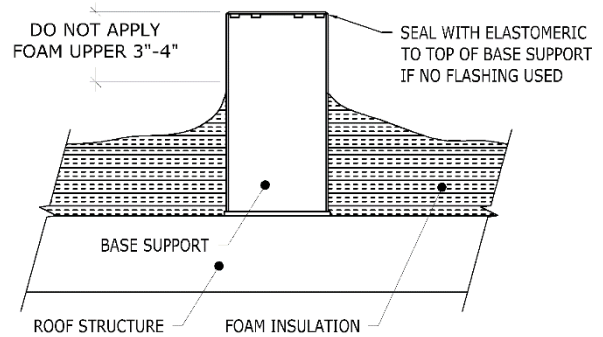

Figure 3

Round Post System:

With the RoofScreen Round Post System, the Slip-On Cap as shown in Figure 4, is designed slip tightly over the Tube Sleeve. There is no clearance for foam or coatings between the Slip-On Cap and Tube Sleeve. For this reason, it is critical that expanding foam or elastomeric coating is NOT applied on the sides of the Round Post within 4" - 6" from the top (see Figure 5).

Foam and/or elastomeric coating should be applied over the Tek Screws that secure the Tube Sleeve to the Round Post. This should be done only after the Round Posts are adjusted to the proper height and secured with the Tek Screws. A rubber Storm Collar is recommended just above the coating and just below the Slip-On Cap.

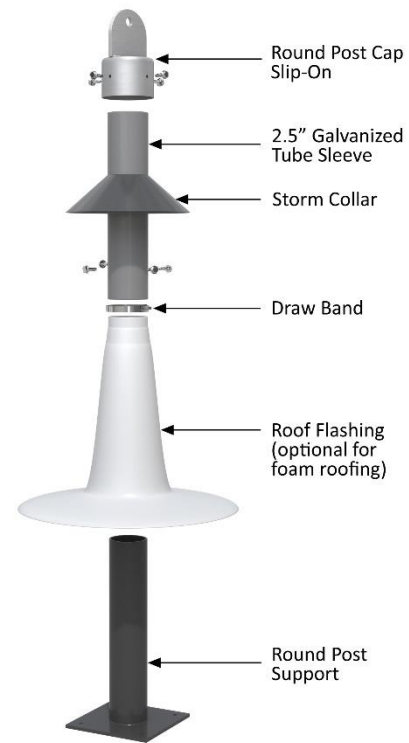

Figure 4

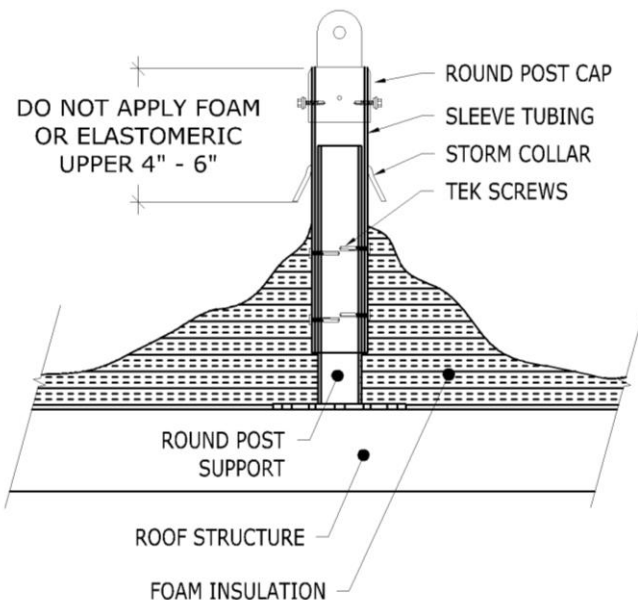

Figure 5