

VISIONGUARD™ LOUVERS INSTALLATION MANUAL



WWW.ROOFSCREEN.COM

Toll Free 866-766-3727

Introduction..... 2

This manual2

Application.....2

System Overview 2

Components.....2

 Louver Blades.....2

 Louver Clip3

 Louver Tree.....3

 Corners3

 Tek 5 Screws (part numbers vary)3

Preparation..... 4

Material Handling.....4

Material Storage.....4

Tools.....4

Installation 5

Review Shop Drawings.....5

 Step 1: Install Louver Trees.....5

 Step 2: Install Louvers.....6

 Step 3: Install Trim or Mitered Corners8

 Step 4: Final Quality Check9

INTRODUCTION

THIS MANUAL

This manual is designed to illustrate the basics of installing VisionGuard™ Louvers. Every job is different and may require variations from the procedures and materials shown in this manual. However, this will give you the concept of how the system is used, and will illustrate the versatility and flexibility of the design.

APPLICATION

Our louvers have the design flexibility to be installed over any type of structure. They work particularly well as equipment screens and have the ability to span farther between vertical supports than any other louver system available. These louvers may also be used as an overhead trellis system. It is important to understand that any installation requires engineering calculations by a licensed structural engineer to ensure its adequacy for the specific conditions that apply.

SYSTEM OVERVIEW

COMPONENTS

The following components are for typical installations. Consult your shop drawings for specifics regarding your project and components that may not be included in this manual.

LOUVER BLADES

We offer 3 styles of louver blades. All 3 styles use the same mounting clips and hardware for installation.

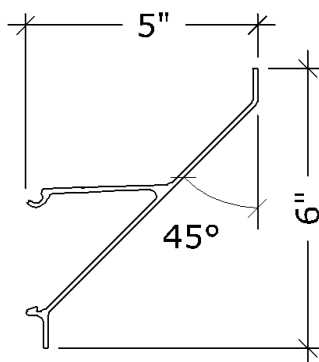

L10 ANGLED

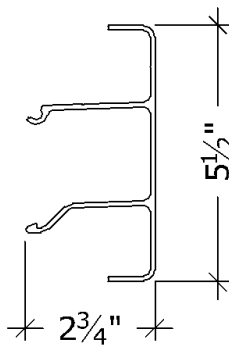

L20 SLATTED

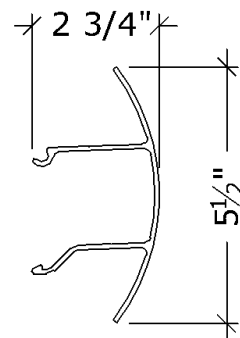

L30 CURVED

LOUVER CLIP

The extruded aluminum louver clip provides a concealed mounting point for VisionGuard™ louver blades. The 3" wide clip can be mounted to any flat surface. The distance between clips controls the blade spacing of the louvers and can be adjusted as desired.

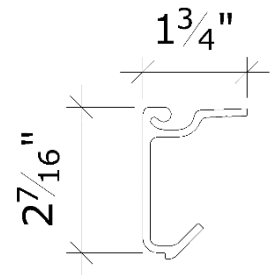

LOUVER TREE

The louver tree is the vertical support member for mounting the continuous louver blades. The tree is pre-assembled by RoofScreen with the clips mounted and spaced to match the louver blade spacing specified on the project.

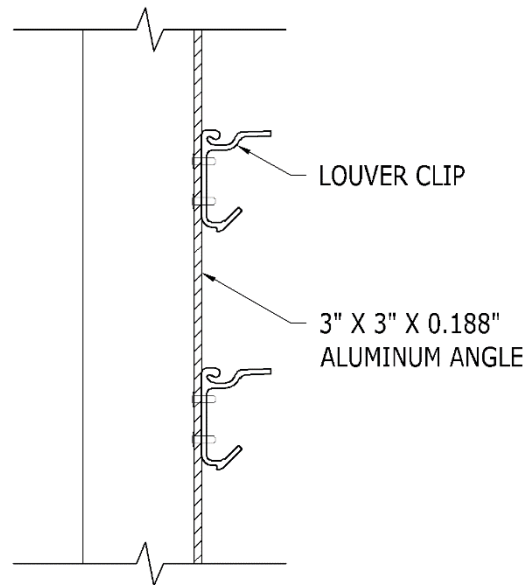

CORNERS

In typical applications, corner trim is installed on inside and outside corners of the louver system. In some cases, pre-welded, mitered corners are provided in lieu of corner trim.

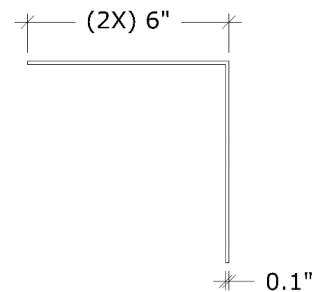

TEK 5 SCREWS (PART NUMBERS VARY)

Tek 5 Self-Drilling Screws have a long drilling point suitable for fastening through multiple layers of aluminum. Types and lengths of screws may vary by project so please carefully review your shop drawings.



PREPARATION

MATERIAL HANDLING

When receiving material, check to see that the shipping documents match the shipment. Count the number of packages and quantities within each package to the extent possible. Check for damage at the same time. If damage or other discrepancies are found, write a note to that effect on the bill of lading, and have it signed by the driver.

Louvers are typically delivered in wood crates to protect them during shipping. Some components including brackets, clips and hardware may be shipped separately in heavy cardboard pallet crates. These materials are heavy and will require a fork lift or crane to unload.

- ! Do not lift wood crates by the slats or cross members. Either use a fork lift from underneath, or use straps around the entire crate.
- ! When using a fork lift, spread the forks as far as possible to balance the load. Drive slowly when moving long crates over uneven surfaces to avoid tipping the load.
- ! When using a crane or any other type of hoist, position the sling straps so that the space between the straps is at least 1/3 the length of the crate. Use sling straps with looped ends, running one end of the strap through the loop at the other end to cinch the crate when lifted.
- ! When setting the load on the roof, put wood blocks under it to protect the roof and allow space to remove the sling straps.
- ! Heavy boxes and crates should be spread out on the roof to avoid overloading the roof structure. Place the material directly over major supports such as beams or trusses.

MATERIAL STORAGE

If the material is going to be stored outdoors for any period of time, we recommend covering it with plastic or tarps. Aluminum has high recycle value so it is recommended that these materials are stored in a secure area to prevent theft.

TOOLS

The following is a list of recommended tools to perform the installation:

1. 200' tape measure
2. String line
3. Levels (large one and 6" "torpedo")
4. Ear plugs
5. Safety glasses
6. Heavy duty extension cords
7. Large Vice Grip Clamps
8. Power drill
9. ½" drive power impact driver
10. Cordless drill/driver gun

11. Self-leveling laser level with tripod.
12. Power skill saw with metal cutting blade
13. Reciprocating saw with metal cutting blade

INSTALLATION

This manual covers the basic techniques for installing VisionGuard™ Louvers. There are many variables that make each project unique and it would be impossible to cover all of them in these instructions. Please use this manual as a general guideline that covers the basic concepts for installing our product. If you have a specific question that is not covered in this manual, or you would like some help with your installation, please feel free to contact us at 866-766-3727.

REVIEW SHOP DRAWINGS

At this point, it is a good idea to read this entire installation manual in conjunction with reviewing the shop drawings. The shop drawings are very detailed and contain specific information about how to properly install the louvers that may not be covered in this manual. It is highly recommended to obtain a full size print of the drawings so all of the details and dimensions are readable.

STEP 1: INSTALL LOUVER TREES

Louver trees are typically mounted to a flat surface like a solid wall, or horizontal girt with a flat face. This type of mounting requires the use of an angle bracket which is supplied with the VisionGuard Louver system. The angle bracket is made out of the same material as the vertical tree, 3" x 3" x .188" aluminum and is typically 3" long. By nesting the angle bracket against the vertical tree angle, but in the opposite orientation to create a Zee shape, the flat leg of the angle bracket can be mounted to the flat surface of the substrate. See Figure 1.

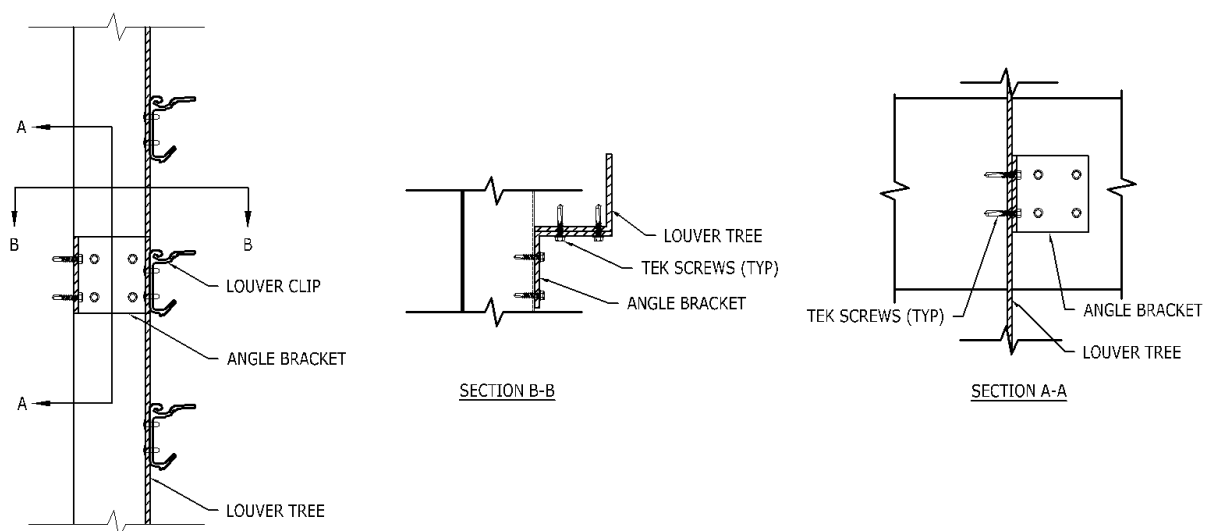

FIGURE 1

Start by installing the first tree at the beginning of a straight run, making sure it is positioned to the desired height for the louver run. Use a level to ensure the tree is perfectly plumb (see Figure 2). Next, install the last tree in the straight run, also making sure it is plumb and at the proper height.

After the first and last trees in a straight louver run have been installed pull a string line from the top of the first tree to the top of the last tree. It is critical for the string line to be perfectly straight as it will be the guide for the remaining trees. If it sags, the louvers will be difficult to install because the trees will not be in line. If the run is long, or it is a windy day, it is recommended to use a laser level for this step.

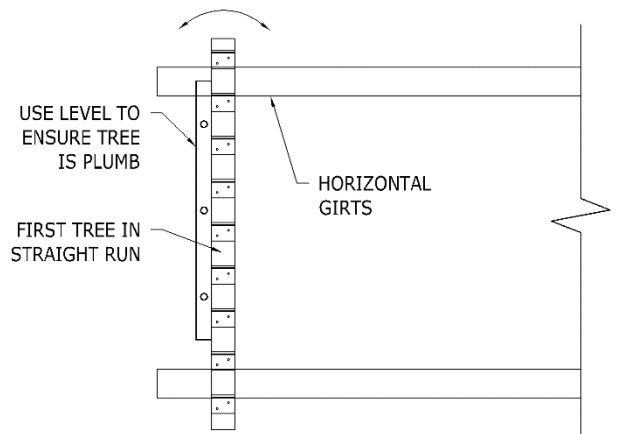

FIGURE 2

Once the string line is in place, or the laser level is set up, install the remaining trees at the spacing specified in the shop drawings. If using a string line, take extra care not to allow the trees to touch the string as they may cause it to go out of level. See Figure 3. If the louvers will have end-to-end splices, it is important to install trees exactly at the splice points. This should be dimensioned on the shop drawings. It may be easier to leave those trees unattached until the louver blades are being installed to ensure their exact location. Repeat this process for each straight run on the project.

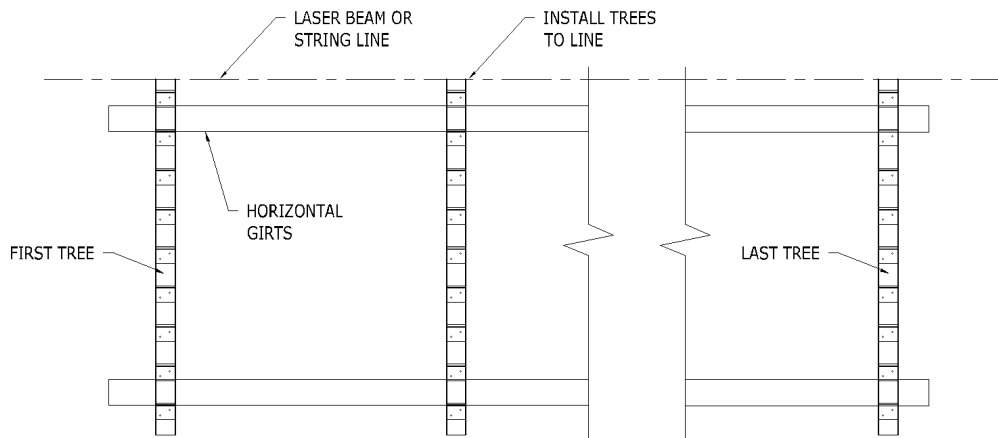

FIGURE 3

STEP 2: INSTALL LOUVERS

The louvers snap into the pre-installed clips on the trees by rotating the louver blade as shown in Figure 4. Install one Tek Screw through the top web of the louver blade into each clip. Because of the way the louvers rotate into place, they must be installed from bottom to top.

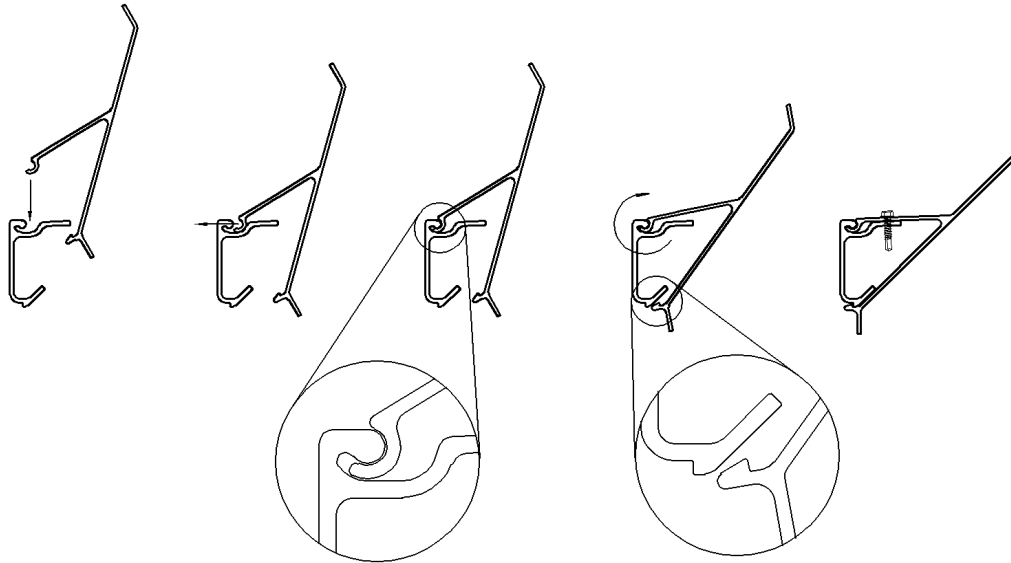

FIGURE 4

Start with the bottom row on a corner or end of a straight run. If your starting point is a corner, certain dimensions must be followed to ensure the corner trims (or mitered corner assemblies, if applicable) will fit properly. If this is the case, please skip ahead to the next section to properly dimension the starting point for the louver blades, then return to this section to continue.

As the louver blades are installed along straight runs, the end-to-end joints must be centered on clips to create a splice. To accomplish this, ensure the louver trees are installed in a location so that each louver being spliced is half way on the clip as shown in Figure 5.

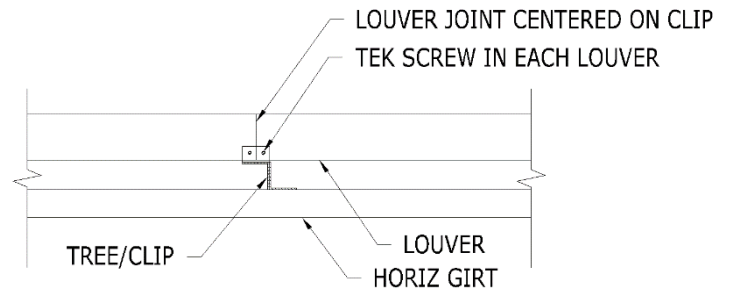

FIGURE 5

Install the remaining rows of louvers as described above.

Consider temperature variations when installing louvers. Large temperature swings of 50° or more can cause blades to expand and contract up to 1/8". In cold temperatures, it is recommended to leave a 1/8" gap between blade splices. In mild temperatures, reduce the gap to 1/16". In hotter temperatures, blades can be butted up next to each other with no gap. Following these guidelines will ensure there is no damage caused by excessive expansion or contraction of the blades.

STEP 3: INSTALL TRIM OR MITERED CORNERS

Corners are finished with either L-shaped trims or mitered corner assemblies. The procedure for each is outlined below.

Corner Trim: When corner trims are being used, the louver blades should extend past the first tree far enough to meet the outside edge of the louvers from the opposite side of the corner as shown in Figure 6.

Place the corner trim in position and install one Tek screw through the trim into each louver row on both legs of the trim (see Figure 7). Trims may be included in your order for ends and inside corners, and this procedure is similar for those conditions. If the louvers are cantilevered far past the last tree, it may be necessary to hold them in the proper position while the screws are installed so they are level with adjacent louver blades.

Mitered Corners: When mitered corners are being used, the first tree on each side of the corner must be placed far away enough from the corner to allow the mitered corner assembly to fit and splice to the louver blade as illustrated in Figure 8. The mitered corners are typically 24" by 24", in which case the trees should be placed at least 28" from the corner to the leading edge of the tree. The louver blades should be installed to extend past the tree by a minimum of 4" and must terminate at an exact dimension to allow a proper fit of the mitered corner assembly. Dry fit and field measure to ensure the mitered corner assemblies will fit evenly and against the louver blades on each side of the corner.

To secure the mitered corners in place, use a 6" splice clip, centered on the butt joint of the louver blade and mitered corner assembly, and fasten with two Tek screws on each side as illustrated in Figure 8.

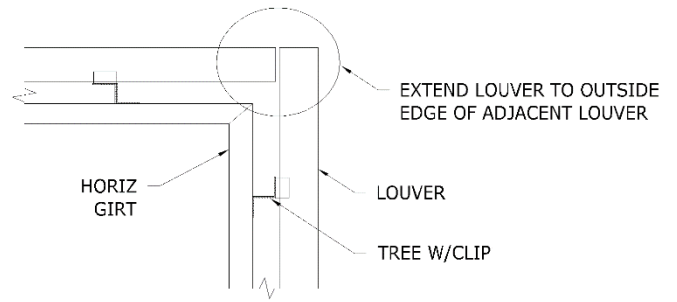

FIGURE 6

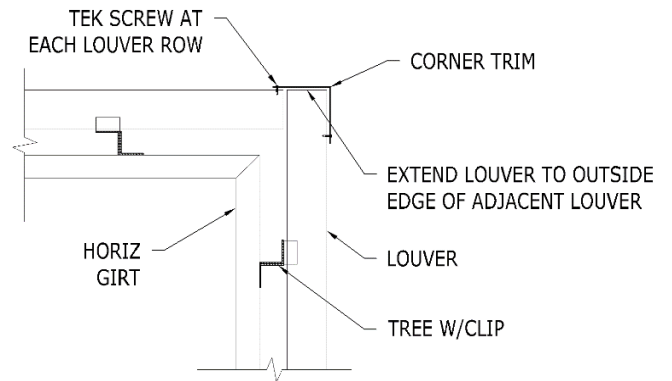

FIGURE 7

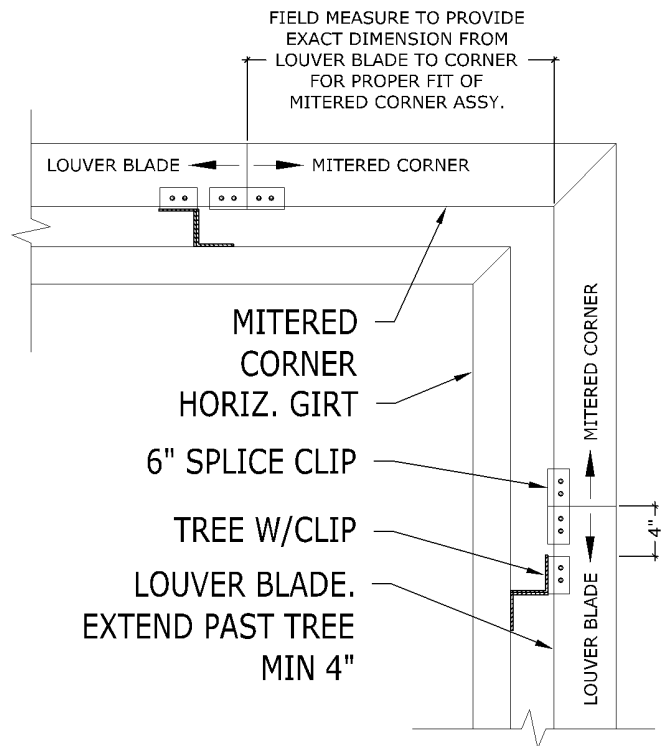

FIGURE 8

STEP 4: FINAL QUALITY CHECK

Perform a final quality control inspection. Check that all the Tek screws have been installed in the louvers and trims. Remove shaving left over from installing Tek screws. Pick up any screws and other miscellaneous items that may have been dropped to prevent damaging the roof membrane should someone step on them.