

RoofScreen LT Frame
Updated 05.09.23

www.roofscreen.com

RoofScreen LT™ Frame

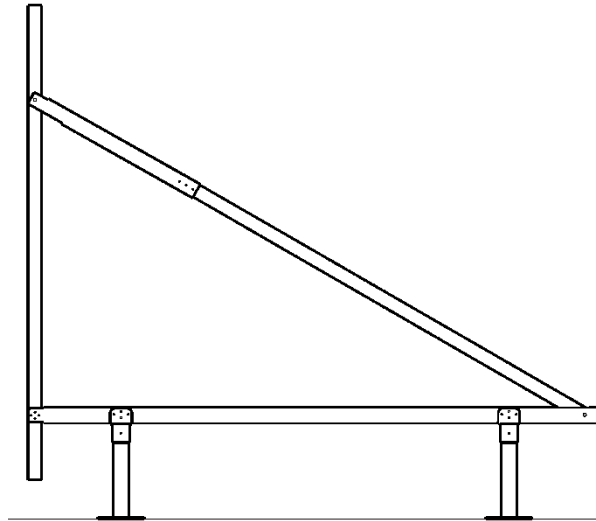

Example of RoofScreen LT™ Frame Configuration

Description:

The RoofScreen LT™ frame is a light-duty frame system that consists of 3 square galvanized tube members and our Square Post Support system, which allows adjustment for roof slope and a watertight connection. This system is adjustable during installation and does not require perfect alignment of the front Post Supports from frame to frame.

Application:

RoofScreen LT™ frames are designed to be used as the primary structural supports for equipment screens on flat and low sloped commercial rooftops. The frames can accommodate virtually any type of face panel to achieve the desired aesthetics for the building. The Square Post Support system can attach in a watertight manner to any type of roof construction, occasionally needing additional structural blocking or reinforcement.

Materials/Components:

Frame Tubes:

- 2" x 2" and 1.75" x 1.75" 14ga. Galvanized steel (ASTM A653).
- Fy = 50ksi (min).
- G90 galvanized.

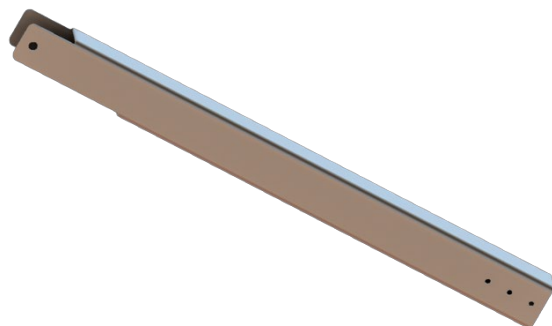

RoofScreen LT Frame
Updated 05.09.23

www.roofscreen.com

Hardware:

- Nuts and bolts used for connectors are corrosion resistant 18-8 stainless steel.
- Tek Screws are carbon steel with premium coating.

Roof Connections:

- Galvanized steel Square Post Support.
- Galvanized steel Square Post Cap.
- Flashing boot matching roof type.
- Flash Clamp and EPDM storm collar for added protection.

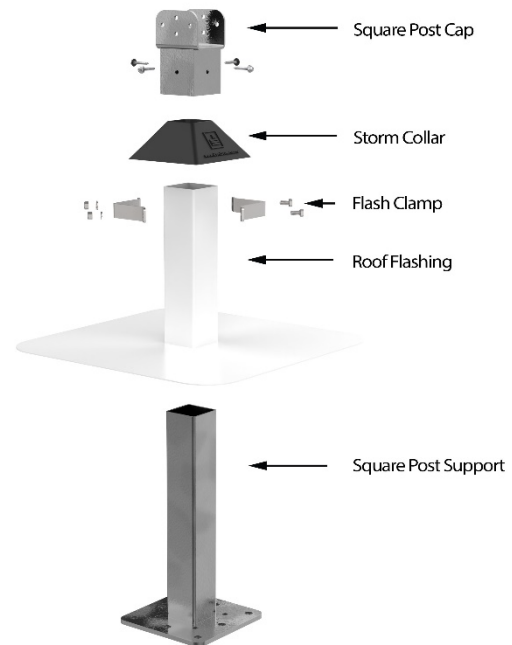

Structural Notes:

The modular design allows the frame configuration and spacing to be adapted to a range of wind loads. Frames can be installed closer together to accommodate varying conditions. Square Post Supports have a fixed connection at the base to the roof structure.

All projects require analysis and calculations by a licensed professional engineer to ensure the design is appropriate for the specific conditions that apply.

Installation:

For typical RoofScreen projects, the frame tubes are delivered pre-cut based on the dimensions of the tallest frame on the project. Depending on the amount of roof slope, some tubes may require field trimming during installation. The installation consists of connecting the tubes together, adjusting for levelness, then locking them together with self-drilling tek screws and through bolts. Slotted and tabbed tube connections allow for frame adjustability and ease of installation. A full installation manual is available, and most projects include full shop drawings showing project specific details.

Warranty:

When the system is designed and engineered by RoofScreen Mfg., we include a 20-year limited warranty.